

SERTOM IN THE WORLD



Press &
Flanging
Machine



sertom M.M. S.p.A.

Via E. Mattei, 16/b • 25060 Collebeato - Brescia - Italia
tel. +39.030.2511234-343 - fax +39.030.2511562
E-mail info@sertom.it • <http://www.sertom.it>



SERTOM FLANGING MACHINE FOR HEADS MODEL FMS

Fully hydraulic bottom flanging machines for the production of edges on flat or crowned tank bottoms. Our range of production reaches 40 mm thickness and 9000 diameter. FMS model can be equipped with or without central hole. The operator can follow step by step the working process reading by digitals. Our FMS can be used either for hot or cold flanging process.

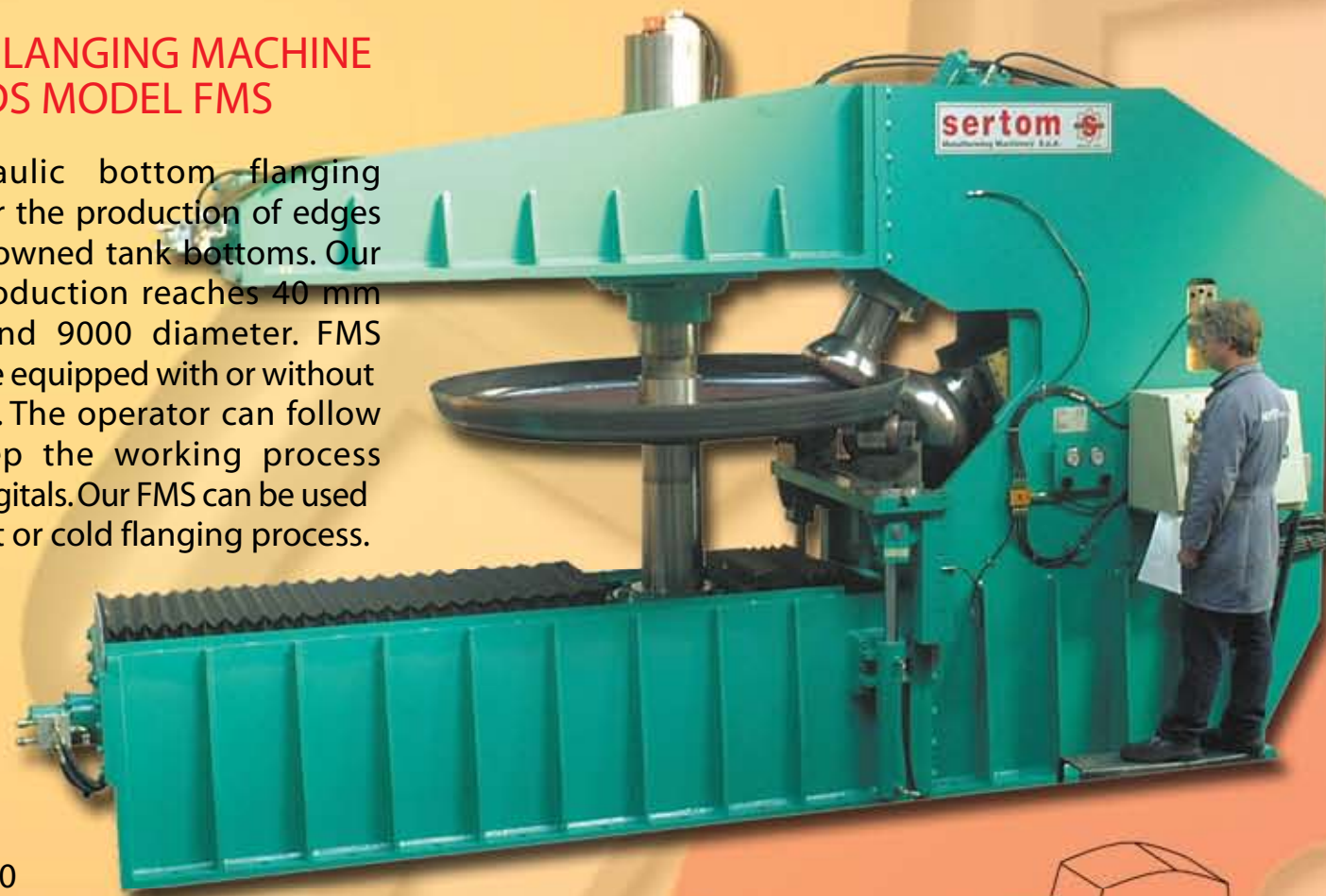

FMS 4000x20



P2MF 4500-400



LAY-OUT COMPLETE FLANGING LINE

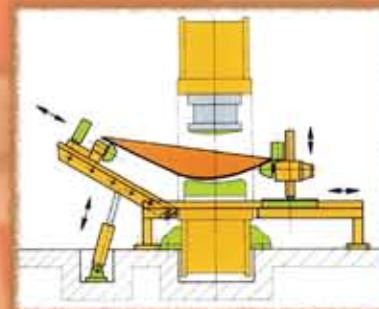

P2MF MANIPULATOR

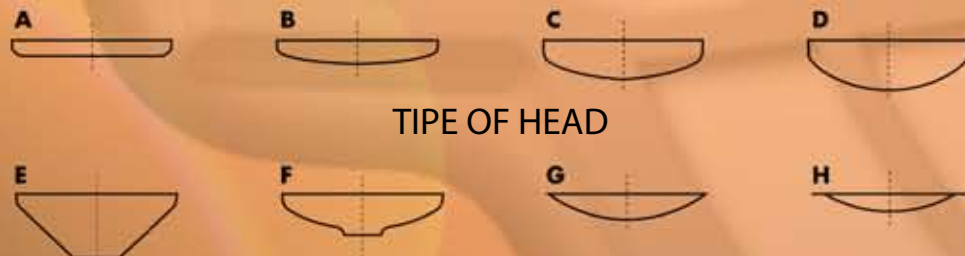

TIPE OF HEAD

SERTOM PRESS WITH OR WITHOUT MANIPULATOR MODEL P2MF

Fully hydraulic press with fixed gantry, having the hydraulic pressing unit with fixed position, machine with power hydro-mechanic group equipped with small flat for the assembling of the dies. This machine is fitted to straightening of plates of big dimensions. Its main feature is the absolute reliability also in presence of extremely hard productive cycles. The manipulator is an independent equipment, completely hydraulic, with translating and rotating movements. Its function is interlocking of main machine. i.e. bottom press. The manipulator operates all movements in synchronism with the press piston. These movemcan be simultaneous or single, and their logical sequence states a cycle for execution of bottoms for tanks, starting with plate descs. All driving devices are centralised in one operative panel, therefore all operations are performed and checked by only one operator.



Model Flangin FMS	Press Combine P2MF	Nominal Force Ton	Distance Uprights	Manipulator Kombination
FMS 4000-6	P2MF 4000-100	100	4.500	
FMS 3000-10	P2MF 3000-150	150	3.500	150
FMS 4000-10	P2MF 4000-150	150	4.500	150
FMS 3000-15	P2MF 3000-200	200	3.500	150
FMS 4000-15	P2MF 4000-200	200	4.500	300
FMS 5000-20	P2MF 5000-250	250	5.500	500
FMS 6000-20	P2MF 6000-250	250	6.500	700
FMS 5000-25	P2MF 5000-300	300	5.500	500
FMS 6000-25	P2MF 6000-300	300	6.500	700
FMS 5000-30	P2MF 5000-400	400	5.500	700
FMS 6000-30	P2MF 6000-400	400	6.500	700
FMS 5000-32	P2MF 5000-500	500	5.500	700
FMS 6000-32	P2MF 6000-500	500	6.500	700
FMS 5000-36	P2MF 5000-600	600	6.500	700
FMS 6000-36	P2MF 6000-600	600	6.500	700
FMS 7000-36	P2MF 7000-600	600	7.500	700
FMS 5000-40	P2MF 5000-700	700	5.500	1000
FMS 6000-40	P2MF 6000-700	700	6.500	1000
FMS 5000-45	P2MF 5000-800	800	5.500	1000
FMS 6000-45	P2MF 6000-800	800	6.500	1200
FMS 8000-45	P2MF 8000-800	800	8.000	1200
FMS 9000-50	P2MF 9000-1000	1.000	9.500	2400



PVM 1000-30-100